

LIMOMETAL d.o.o.

Mala Lisa bb, 77220 Cazin, BiH

Tel: +387 (0)37 512 942,

+387 (0)37 513 503

Fax: +387 (0)37 539 060

E-mail: info@limometal.com

Web: www.limometal.com

AUTO GARAŽA “LIMOMETAL”

Montažno-demontažna garaža dimenzija 6,23 m x 3,07 m x 2,30 m



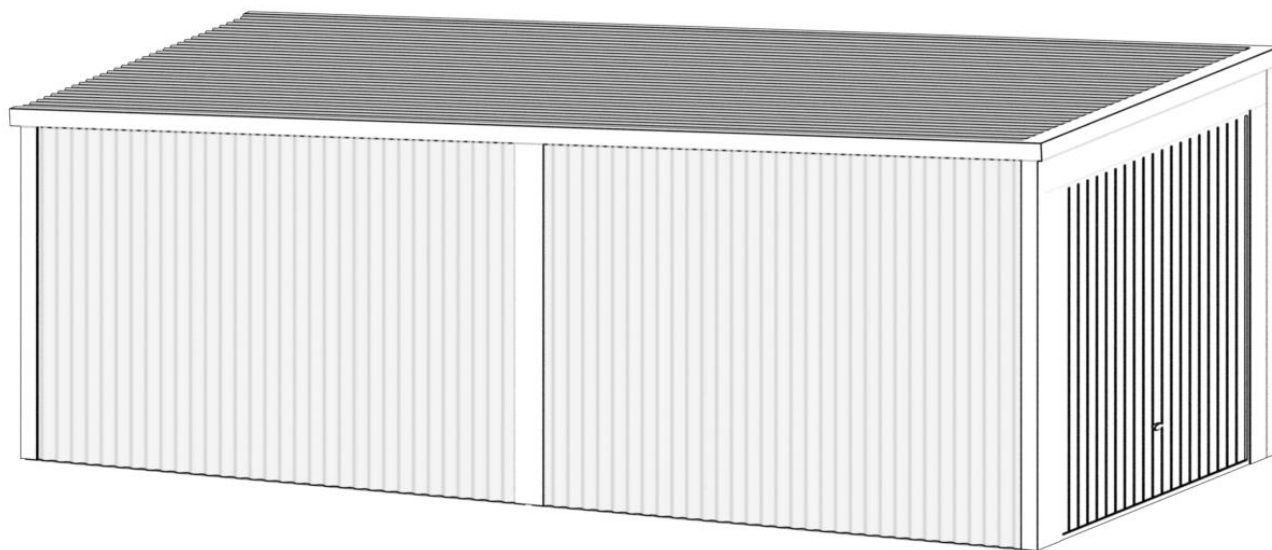

Garaža je izrađena (osim vrata) od pocinčanog čeličnog sinusno profilisanog lima, na spojevima ojačana limenim čeličnim pocinčanim profilima i nosive krovne grede od pocinčanih limenih profila.

Ukupna težina svih elemenata sa paletom je cca 550 kg.

Dimenzije vrata su 245 cm x 197 cm. Garaža se montira na ravnu (betonsku) podlogu koja bi trebala biti minimalno dimenzija 6,45 x 3,30 m.

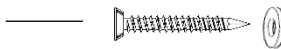

Pričvrсни materijal:

1. Turbo vijak 7,5 x 92 mm + podloška x 24 kom. 
2. Vijak 4,2 x 13 mm RAL 7016 x 100 kom. 
3. Vijak 5,5 x 19 mm x 150 kom. 
4. Vijak 5,5 x 19 mm sa podloškom x 230 kom. 

Sastavni dijelovi auto garaže:

- | | |
|--|---|
| A - Zadnja stranica x 1 komad | M - Zadnja lajsna x 2 komada |
| B1 - Bočna stranica (desna) x 1 komad | E - Bočne krovne lajsne x 4 komada |
| B2 - Bočna stranica (lijeva) x 1 komad | S - Krovna zadnja spojna lajsna x 2 komada |
| C1 - Bočna stranica (desna) x 1 komad | V - Krovna prednja spojna lajsna x 2 komada |
| C2 - Bočna stranica (lijeva) x 1 komad | T1 - Zadnja spojna lajsna (desna) x 1 komad |
| D - Prednja stranica x 1 komad | T2 - Zadnja spojna lajsna (lijeva) x 1 komad |
| G - Krovna greda x 3 komada | Z1 - Srednja spojna lajsna (desna) x 1 komad |
| R - Krovna greda x 1 komada | Z2 - Srednja spojna lajsna (lijeva) x 1 komad |
| H - Srednja greda x 1 komad | N1 - Prednja spojna lajsna (desna) x 1 komad |
| Sinusne krovne table x 6 komada | N2 - Prednja spojna lajsna (lijeva) x 1 komad |



Korak 1		Betonska podloga	
---------	--	------------------	--

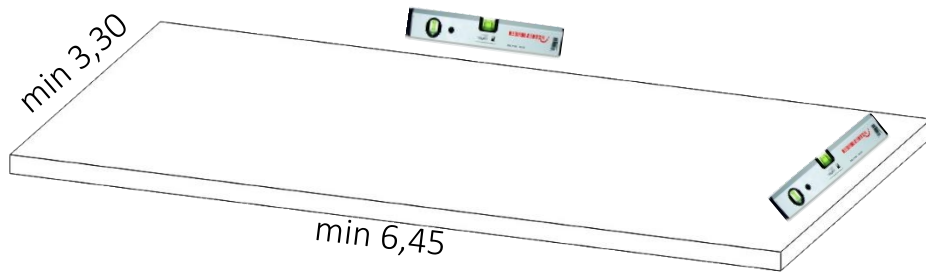

Korak 2	A + B1	Vijak 5,5 x 19 - 6 kom 	Bit 8 mm 
---------	--------	---	---

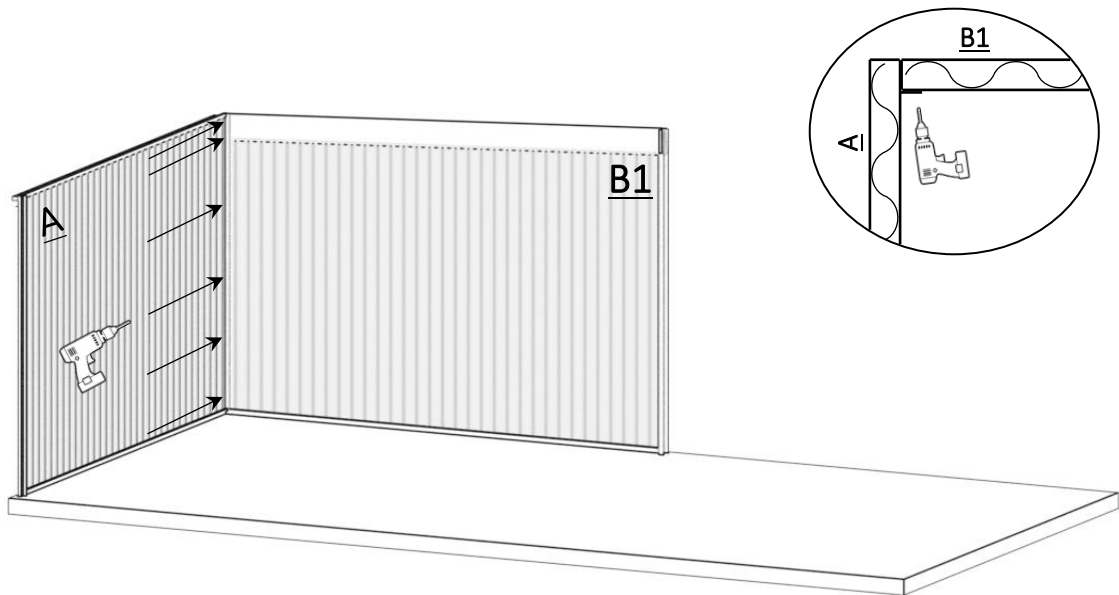

Korak 3	A + B2	Vijak 5,5 x 19 - 6 kom 	Bit 8 mm 
----------------	--------	---	---

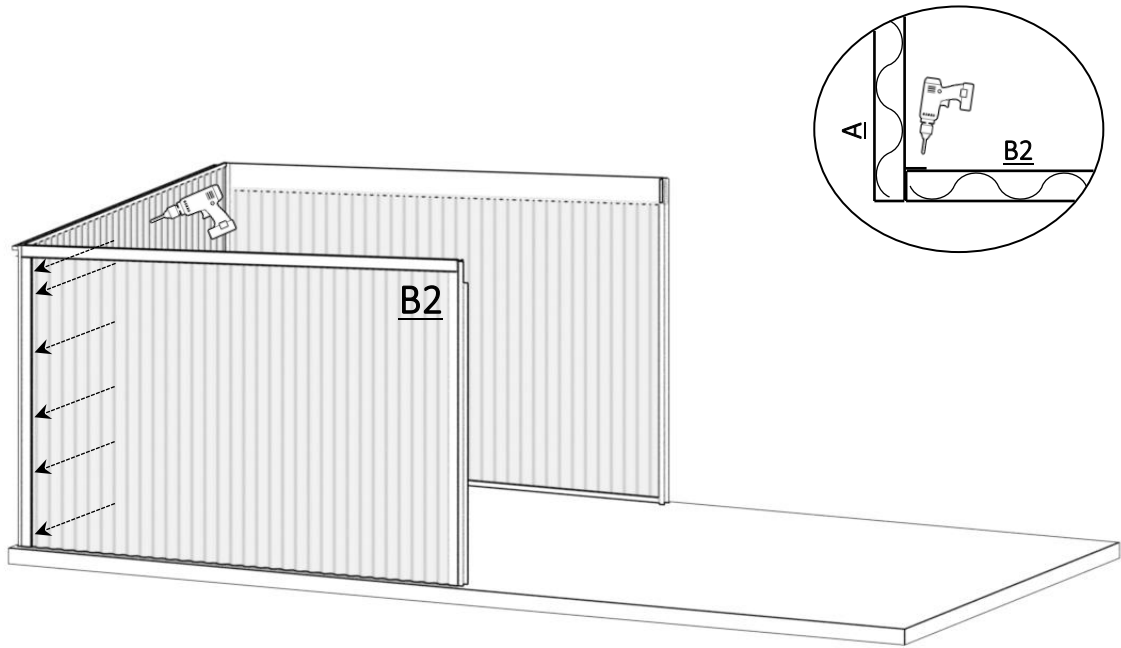

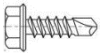
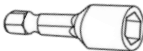
Korak 4	G – 2 kom	Vijak 5,5 x 19 - 40 kom 	Bit 8 mm 
----------------	-----------	--	---

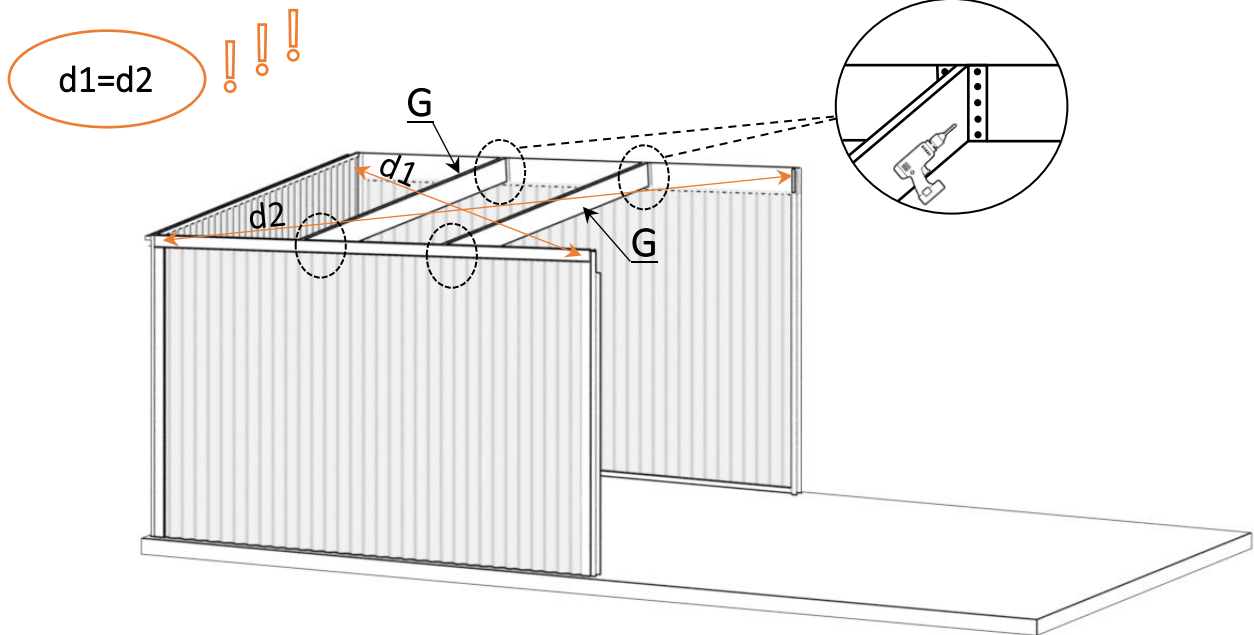

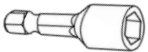
Korak 5	B1 + C1	Vijak 5,5 x 19 - 5 kom 	Bit 8 mm 
---------	---------	---	---

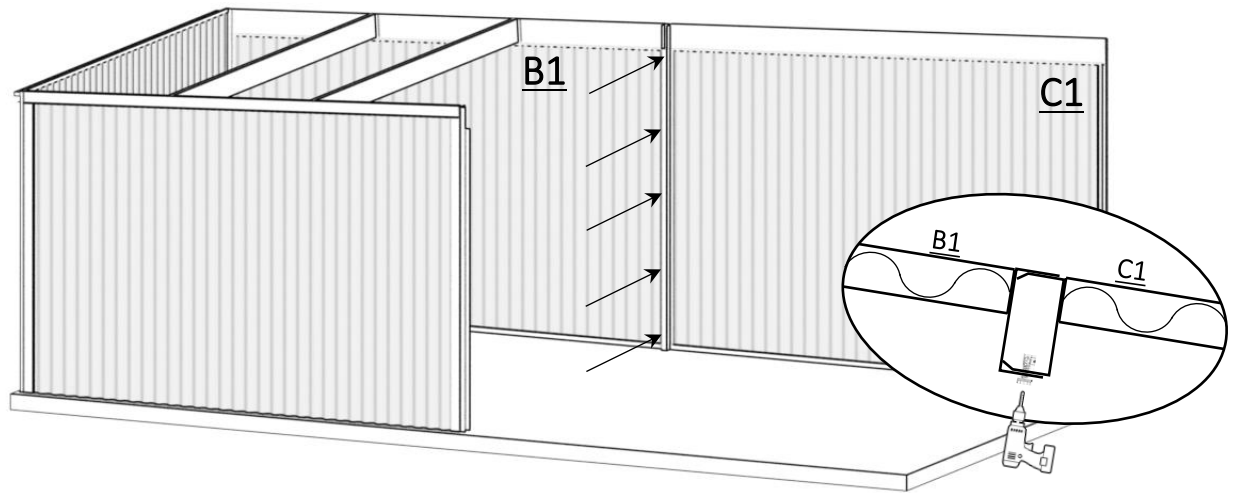

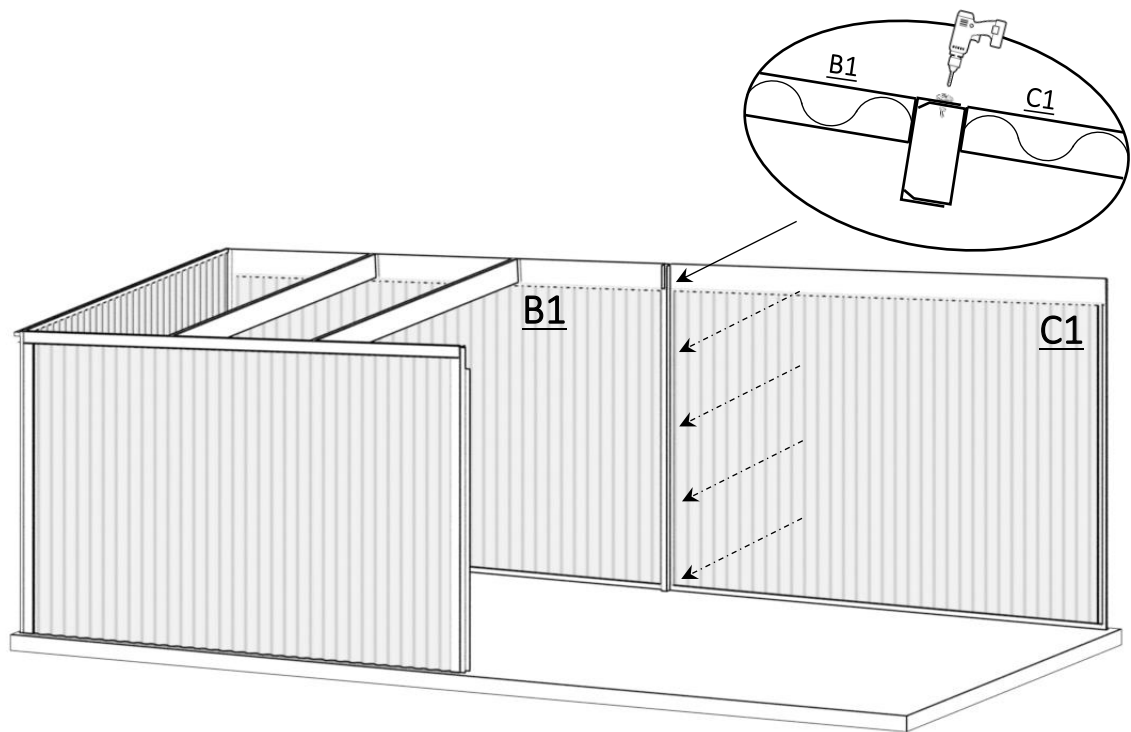

Korak 6	B1 + C1	Vijak 4,2 x 13 - 5 kom 	PH-2 
---------	---------	--	--

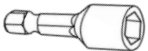

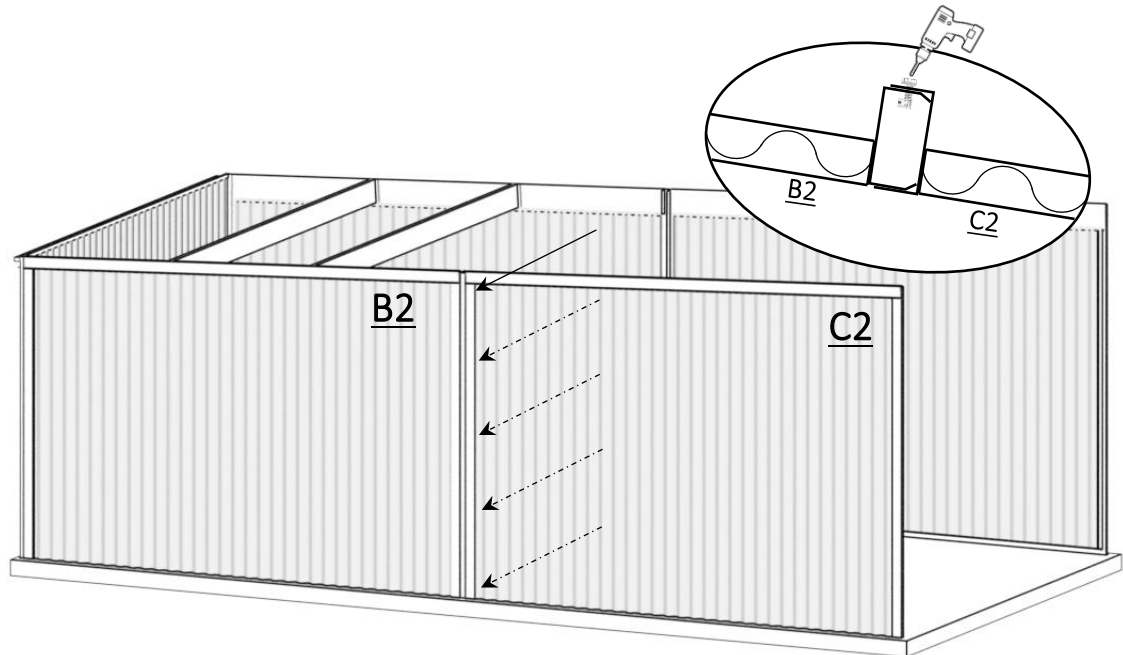

Korak 7	B2 + C2	Vijak 5,5 x 19 - 5 kom 	Bit 8 mm 
----------------	---------	---	---



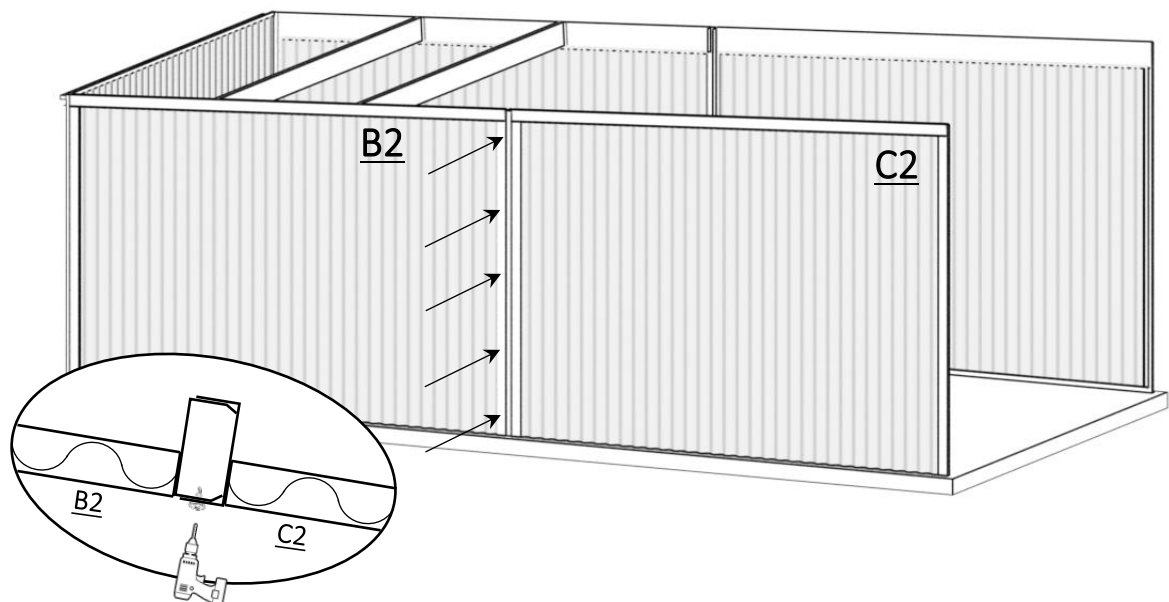

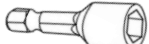
Korak 8	B2 + C2	Vijak 4,2 x 13 - 5 kom 	PH-2 
----------------	---------	---	---



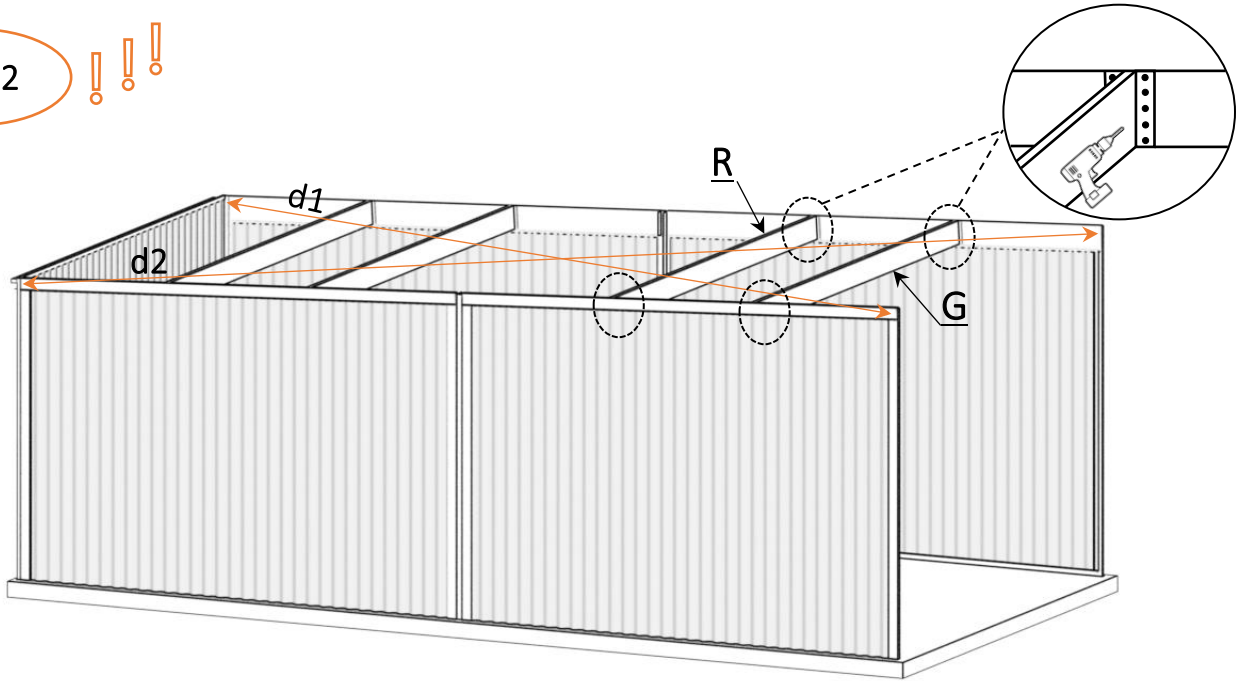

Korak 9	R – 1 kom G – 1 kom	Vijak 5,5 x 19 - 40 kom 	Bit 8 mm 
----------------	------------------------	--	---

d1=d2 

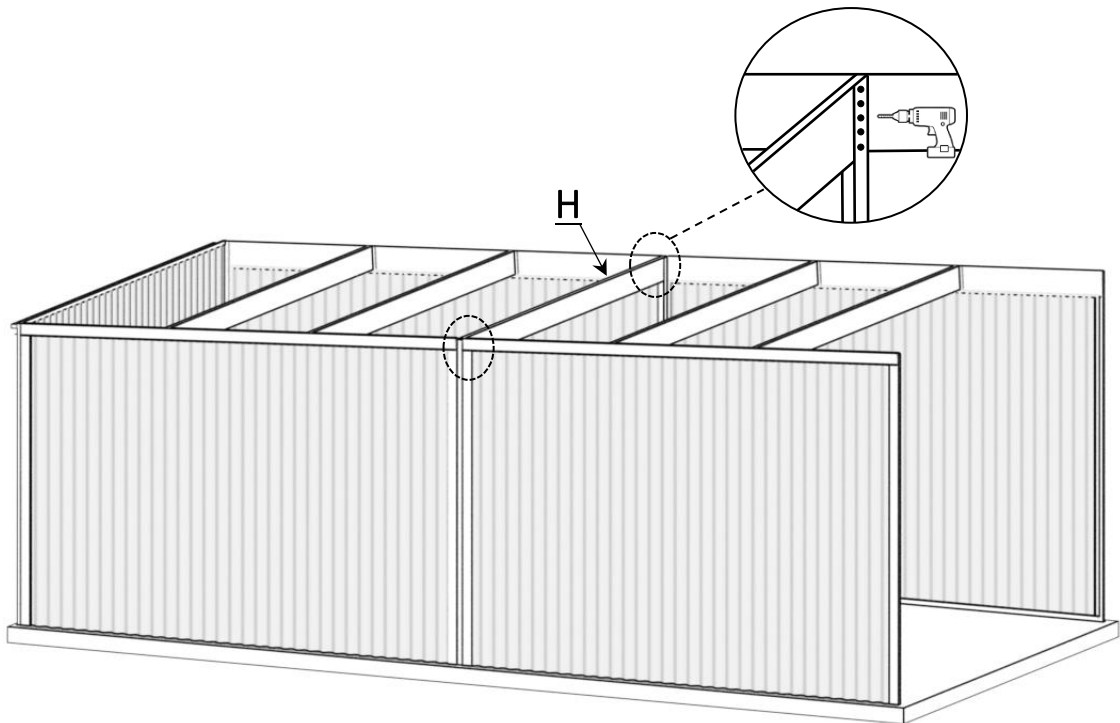

Korak 10	H – 1 kom	Vijak 5,5 x 19 - 20 kom 	Bit 8 mm 
-----------------	-----------	--	---

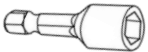

Korak 11	D + C1,C2	Vijak 5,5 x 19 - 12 kom 	Bit 8 mm 
-----------------	-----------	--	---

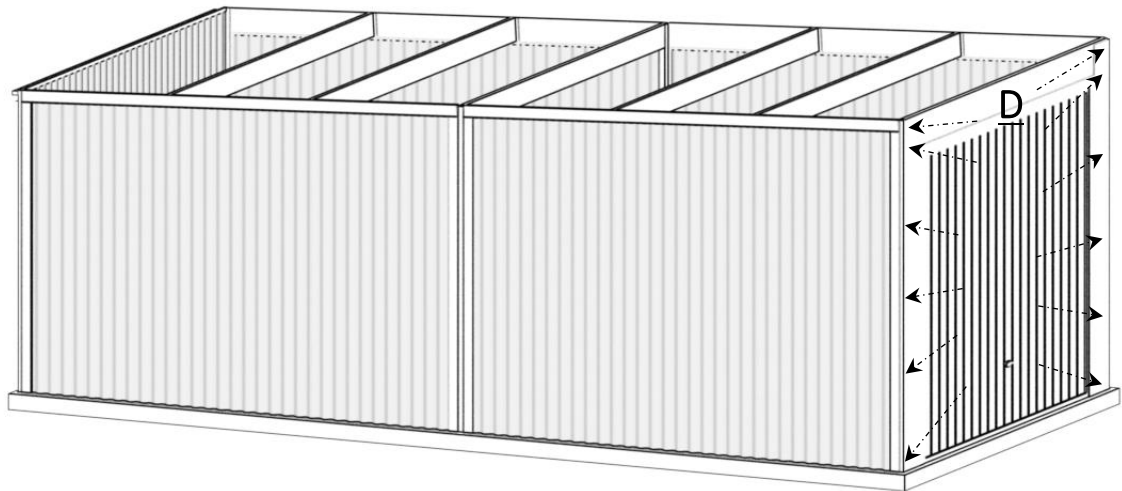
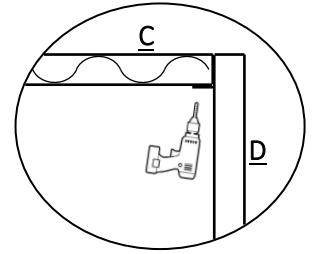

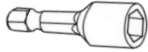

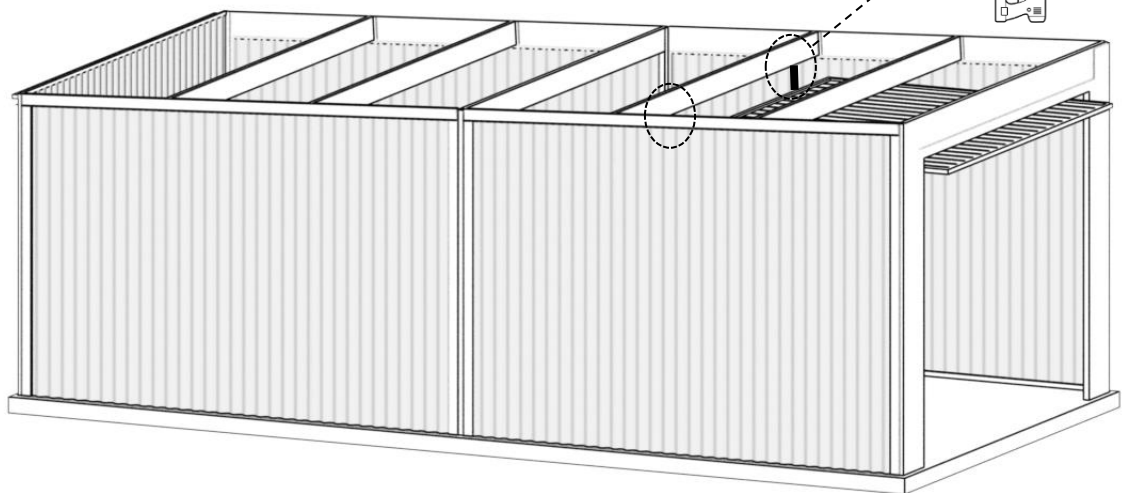
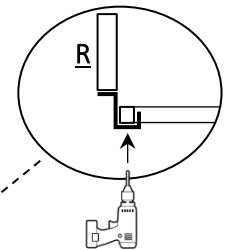
Korak 12	R + nosač vrata 2 kom	Vijak 5,5 x 19 - 2 kom 	Bit 8 mm 
-----------------	--------------------------	---	---

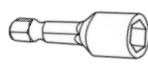

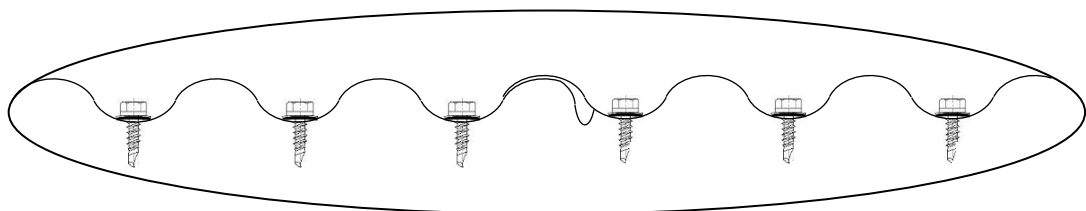
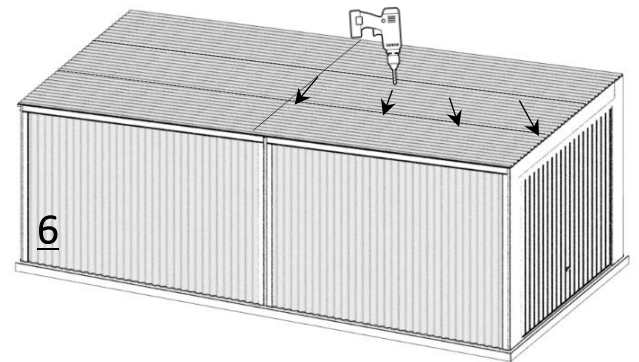
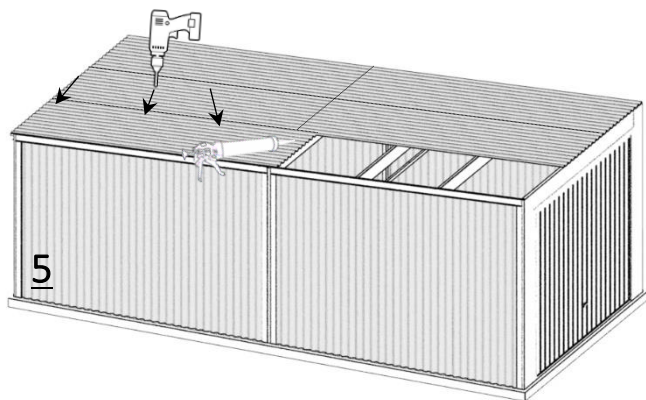
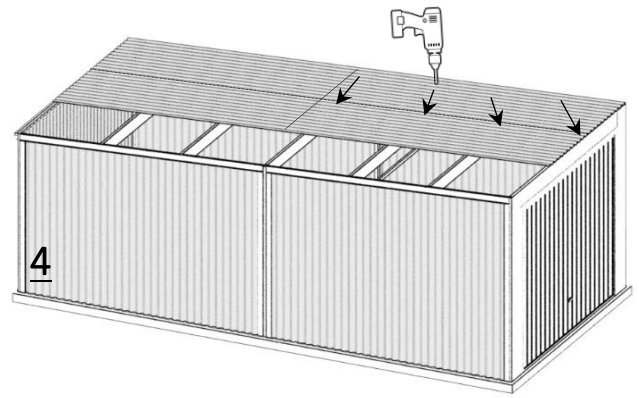
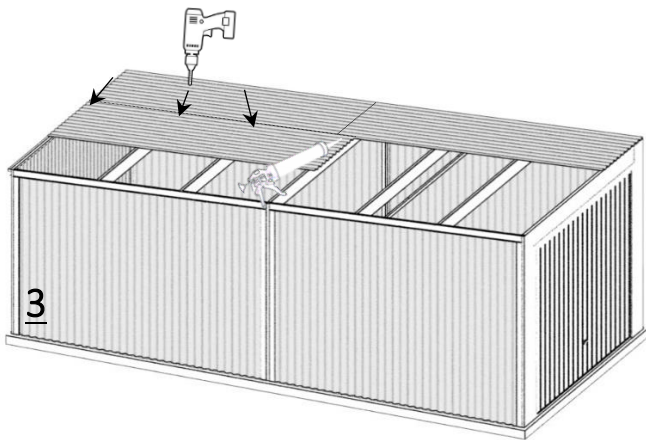
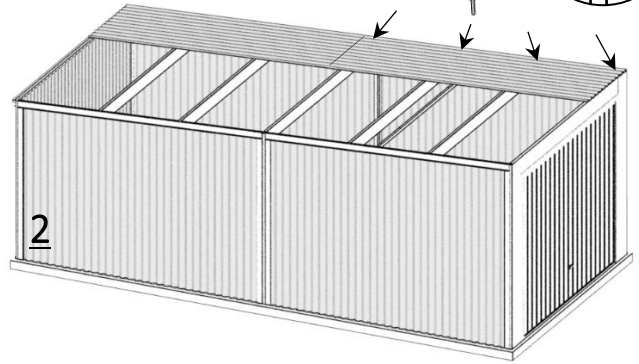
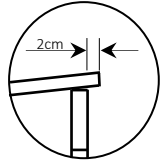
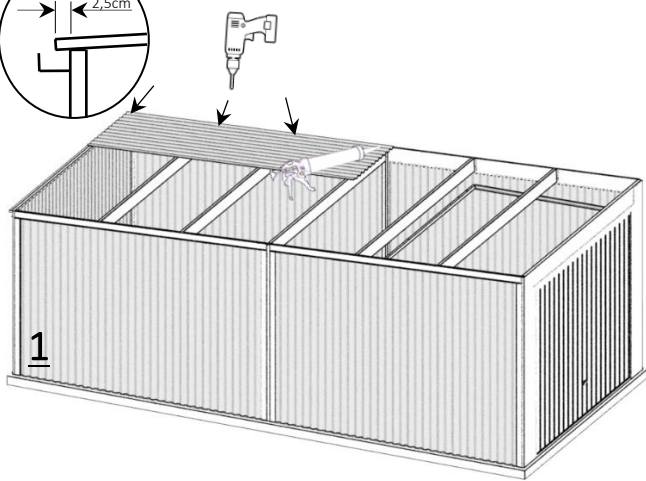
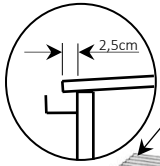

<p>Korak 13</p>	<p>6 kom</p>	<p>Vijak 5,5 x 19 sa podloškom - 231 kom</p> 	<p>Bit 8 mm</p> 
------------------------	--------------	--	---



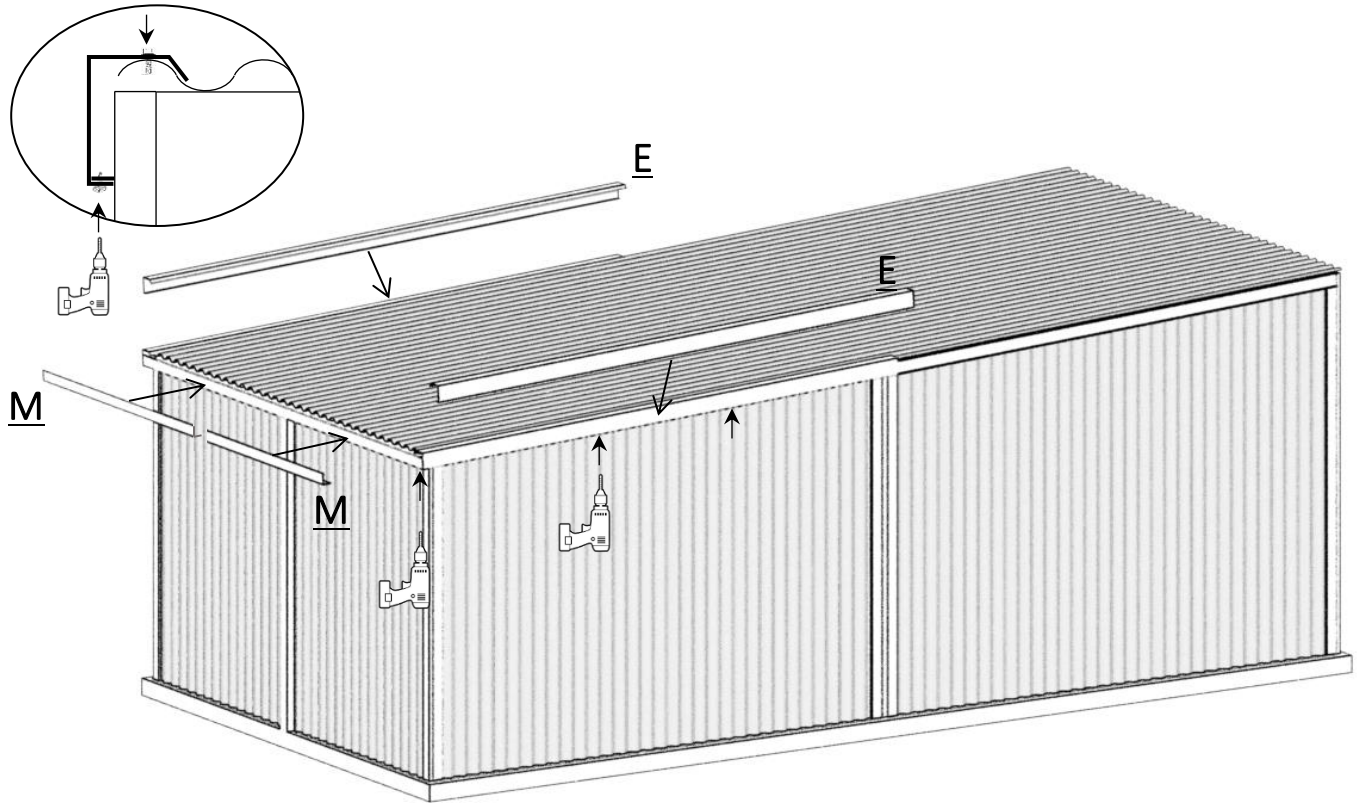

Korak 14	E – 2 kom M – 2 kom	Vijak 4,2 x 13 - 10 kom 	HP - 2 
-----------------	------------------------	--	---



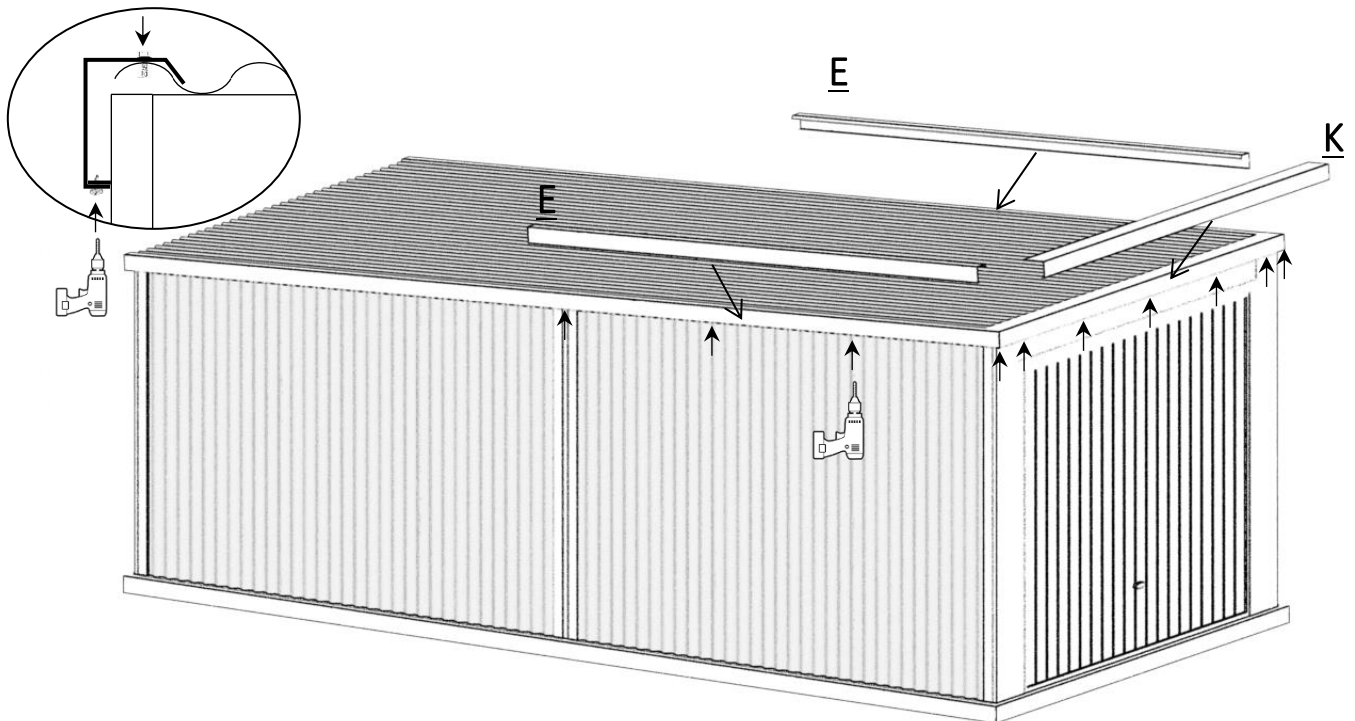

Korak 15	E – 2 kom K – 1 kom	Vijak 4,2 x 13 - 12 kom 	HP - 2 
-----------------	------------------------	--	---

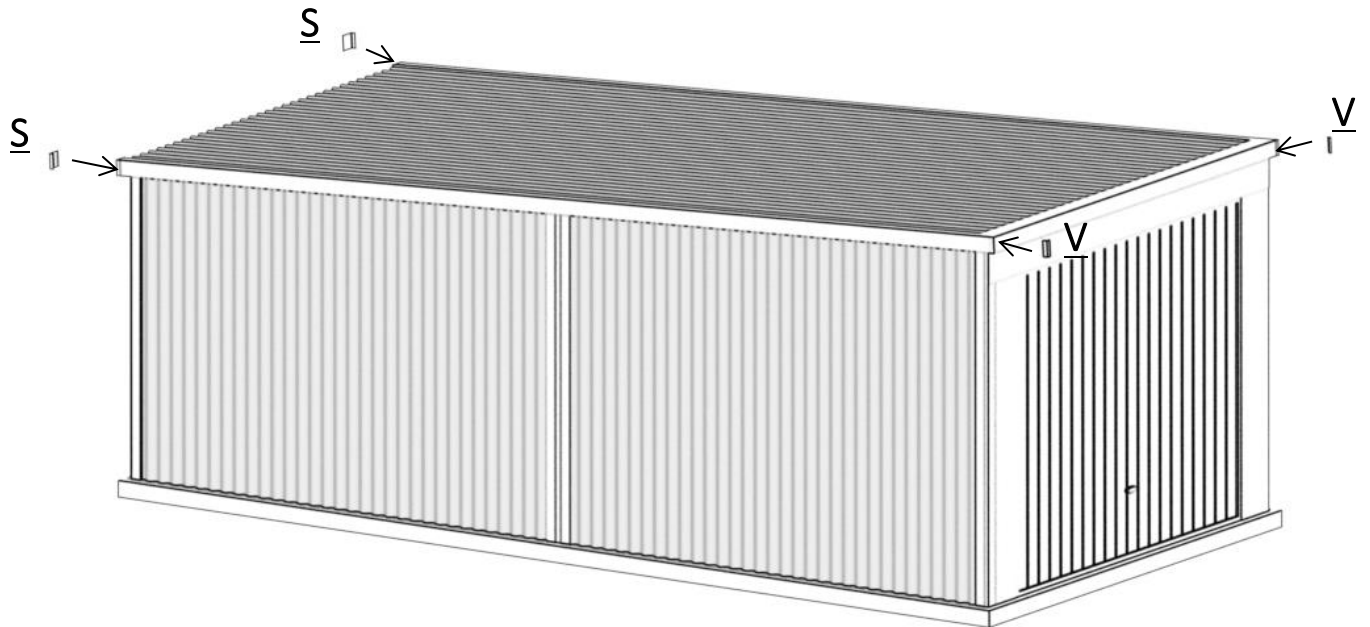

Korak 16	S – 2 kom V – 1 kom	Vijak 4,2 x 13 - 12 kom 	HP - 2 
-----------------	------------------------	--	---



Korak 17	T – 2 kom Z – 1 kom N – 1 kom	Vijak 4,2 x 13 - 36 kom 	HP - 2 
-----------------	-------------------------------------	--	---

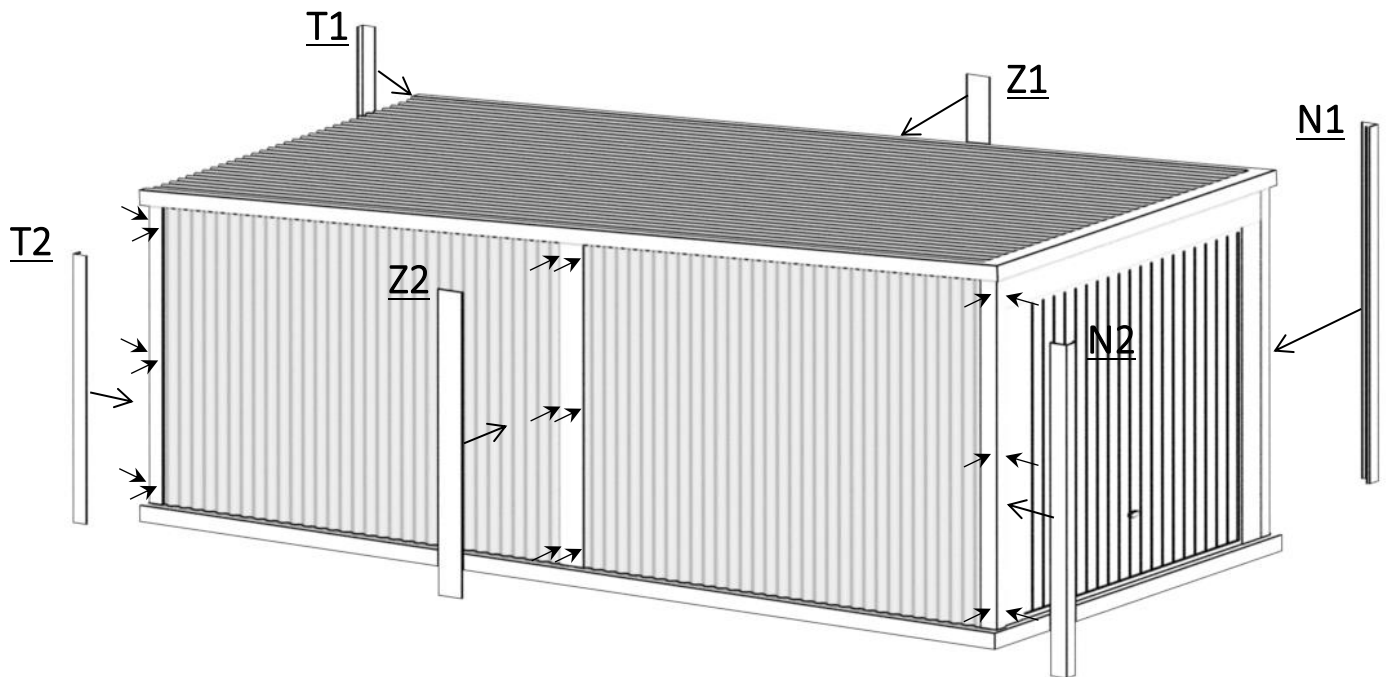

Korak 18

Turbo vijak 7,5 x 92 - 24 kom



TOREX

